

DELIVERING PRODUCT DEVELOPMENT INSIGHT

FINDING THE RIGHT TECHNOLOGY
TO PROVIDE EXECUTIVE VISIBILITY

LIFECYCLE

INSIGHTS

NOW MORE THAN EVER, EXECUTIVES NEED VISIBILITY

Today, product development is more complex than ever.

Technologies being integrated into products are advancing at a breakneck pace. Specialized suppliers with niche expertise are playing more prominent roles in development. Manufacturers are connecting to sensors in their products and streaming data to the cloud. Technical centers and manufacturing sites, both internal and supplier, are increasingly spread across the globe.

In this increasingly complex environment, hints of early problems can arise from myriad sources, but they can be easily overlooked. Repetitive failures in a specific unit test might hint at an integration issue. Fit problems in test production runs might be a clue of tolerance difficulties. Higher than expected component rejection rates might be an early sign of a supplier's inadequate quality procedures. If these and other issues aren't caught early, they bloom into full-blown catastrophes, running a project off schedule and causing costs to skyrocket. Despite these challenges, executives are still expected to deliver high quality products on time and under budget.

The means to mitigate the issues that can derail product development lies in executive visibility. Issues in development always have early hints and clues. If executives can catch those signs early enough, they can develop a corrective action plan to address them before those problems become a real threat. The trick, of course, is to find those trends as they emerge.

Interestingly enough, the evidence of these product issues resides in something each company already owns: their big data. Clues exist in their enterprise systems such as Product Lifecycle Management (PLM), Enterprise Resource Management (ERP) and many others. Yet signs also can be found in the data companies are streaming from the sensors on their products as part of the Internet of Things (IoT) movement. However, it is not easy to uncover these hints and gain actionable insight.

The challenge in gaining executive visibility into these issues is that those trends are buried in the vast amount of information that exists in those systems and sensor data. Executives need to be able to quickly, easily and flexibly traverse that information and data. While many of these enterprise systems provide powerful reporting capabilities that deliver value to numerous roles in development, they have limitations that curb their effectiveness in delivering executive visibility. In contrast, Product Data Analytics solutions provide the right mix for the job.

Therein lies the purpose of this eBook. Here, you will find more details on the factors that increase the complexity of development. You will find more on the key capabilities needed to deliver such insight.

It has always been a challenge to gain visibility in product development. However, with the right tools, it is now easier than ever before.

INCREASING PRODUCT DEVELOPMENT COMPLEXITY

There is no doubt about it—developing modern products is a complex balancing act. Executives have to find a way to deliver new products on time, hit demands for high quality, and protect profitability along the way. That can be done with the right insight. However, to do that, it is important to understand why modern development is so complicated.

GROWING TECHNOLOGY COMPLEXITY IN PRODUCTS

One factor contributing to the increasing complexity of development is the technologies being incorporated into today's products. Trends in electronics, including ongoing miniaturization, low power requirements, and the need for greater heat dissipation, make it harder to accommodate the ever-increasing demand for computer power in products. The explosion of software in products raises integration issues, as those applications must seamlessly work with the electronic hardware and other systems in the products. The driver in all this, of course, is the need to offer innovative and distinctive products.

Integrating all of these technologies into a single seamless product is rarely easy. Engineers and technicians from different teams must collaborate to ensure everything works together. A failure to navigate that difficulty almost guarantees there will be at least one, if not more, significant delays in the schedule or an unforeseen cost in the development budget. Incorporating more complex technologies into products is a necessary risk.

The increasing complexity of technology in products is no passing trend. It is a challenge that will flummox executives for decades to come. And it can directly undermine executive efforts to execute product development seamlessly.

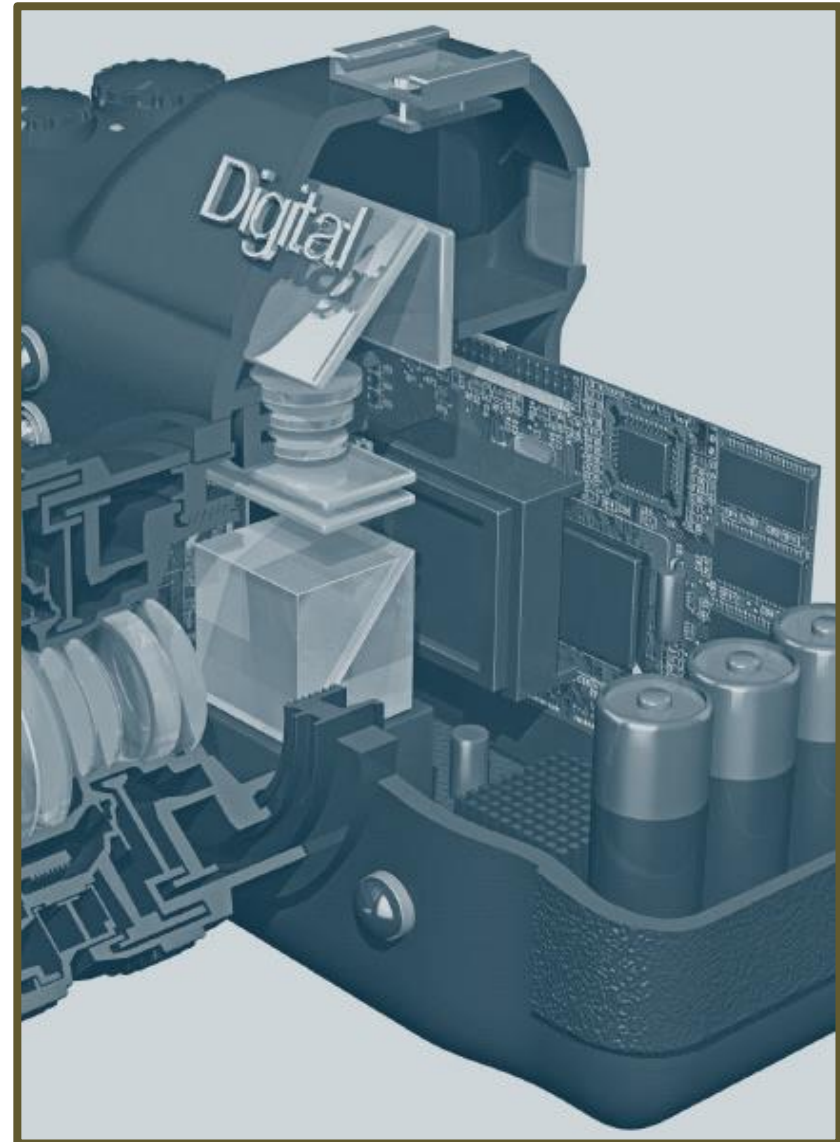

THE ADVENT OF THE INTERNET OF THINGS ERA

There's no doubt that the emergence of the IoT will permanently change not only the content of products, but how they are developed. The integration of the IoT into products is already a reality, offering a means by which manufacturers can offer innovative new capabilities. However, it also lets companies completely reimagine their business models, enabling them to disrupt markets or stave off competitors. It is simultaneously an opportunity and threat.

In the context of product development complexity, there is no doubt that the IoT is a complicating factor. From a development perspective, companies must determine the best way to instrument their products with the right sensors, to capture the right data, and to stream that information to the right storage.

While this trend could technically be part of the *Growing Technology Complexity in Products*, it is different in one critical way: its enabling technologies extend beyond the product. For the rest of the product's operating life, it will need to connect to some storage or software that lives in the cloud. This reality is another complicating factor because the product is no longer self-contained. Any changes to the product or the connected off-product assets must be coordinated carefully.

All of these issues add up to more risk. Companies must determine the best way to prototype IoT-enabled products and identify any outstanding problems without threatening the development schedule or upsetting the budget.



RISE OF SUPPLIERS TO PROMINENT ROLES

Suppliers have always played a critical role in product development. However, original equipment manufacturers are now turning to suppliers that provide expertise in specific domains, both to provide components and to design and deliver entire systems. These suppliers are often distributed around the world, and they operate technical centers and manufacturing facilities with different cultures, operating procedures, and methods.

This new reality introduces another factor that complicates product development. Executives must not only identify and resolve supply chain issues within their own company, but also those in a distributed network of suppliers spread across the globe. Visibility lets them head off product issues earlier, before they derail good development projects.

THE INHERENT NATURE OF DEVELOPMENT

The last factor that is making product development more complex isn't a new one. In fact, it is as old as design itself. It is the simple reality that designing a product requires iteration and experimentation. Developing new products is an act of trial and error. An engineer might attempt one design configuration, only to see it fail. That same engineer might try a second iteration and verify it is minimally feasible. The third endeavor might succeed wildly, representing a true innovation. Ultimately, design is an exercise of developing something new, the success of which is not guaranteed.

This reality, that development is inherently tumultuous, can easily disrupt any meticulously planned schedules and budgets. Therein lies the risk that executives must manage—taming the turbulent nature of development so it adheres to a plan.

Executives can, of course, mitigate this risk. They can move that experimentation and validation to a separate research and development organization. They can select technologies for new product development more conservatively, reducing their risk. However, in today's highly competitive environment, executives are under pressure to make breakthrough products. That, in turn, demands innovation. The key is to find the right balance.

TAKEAWAYS

A variety of factors make product development more complex today, threatening executive's ability to make new products on time, fulfill demands for high quality, and preserve profitability. Visibility into product development empowers executives by allowing them to identify issues early and take corrective action.

BARRIERS TO GAINING INSIGHT INTO PRODUCT DEVELOPMENT

By identifying issues early, executives can make immediate corrections so that problems never bloom into full-blown catastrophes. This preserves the organization's ability to deliver high quality, on-time, on-budget products. All of this relies on an executive's ability to gain accurate visibility into the current state of product development. That means they need to catch the hints, clues, and signs of issues and follow them to the root cause.

Unfortunately, there are some barriers to gaining visibility into product development. Any solution that is considered must be able to address these issues.

BIG DATA FROM IOT-ENABLED PRODUCTS

Soon enough, there will be billions of products connected to the IoT. Each will have unique addresses. Each will be streaming data. Once companies start collecting data from these products, they quickly realize they are facing a *massive* amount of data. It is a veritable ocean of information, within which there are critical hints of product performance issues and development problems. However, finding such trends is extremely challenging, as they are literally buried in that data.

Now, and increasingly in the future, any solution providing product development insights must be able to connect and analyze big data from IoT-enabled products.

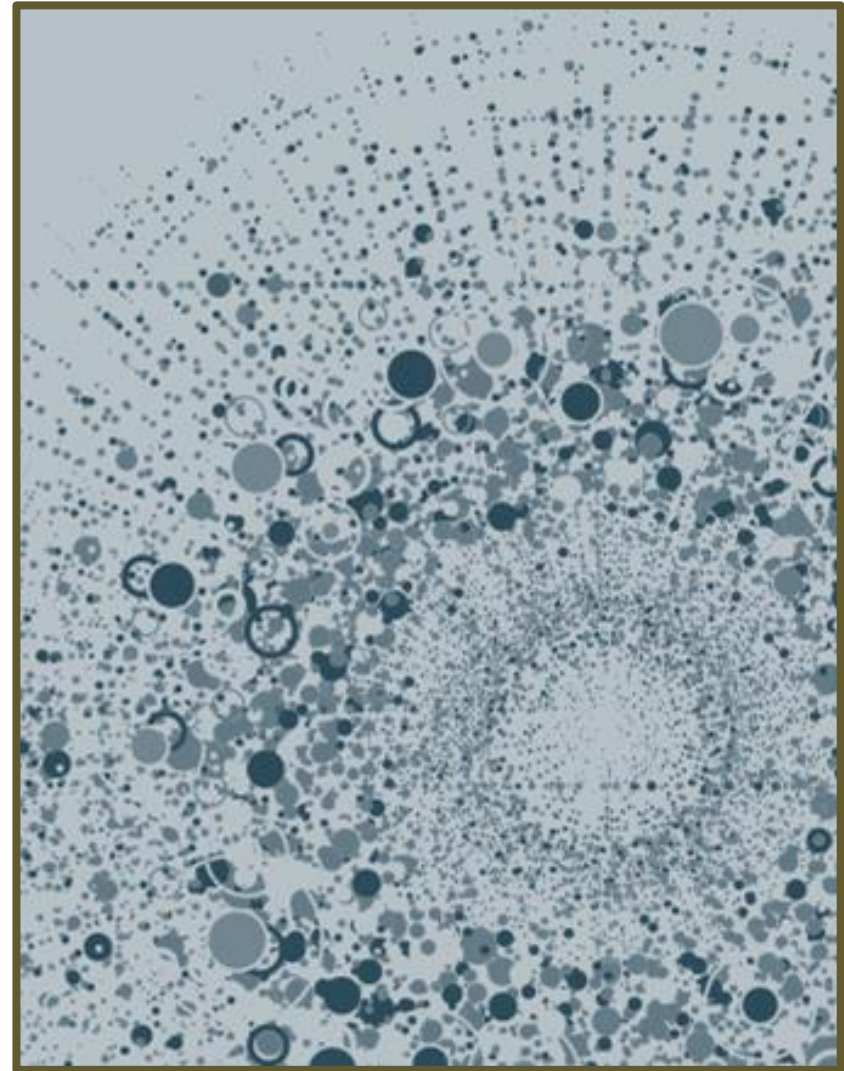

BIG DATA SCATTERED IN ENTERPRISE SYSTEMS

Another source of big data exists as the information in all of the enterprise systems that support product development, including PLM, ERP, sourcing, and many other systems. There could be thousands of problem reports. There could be tens of thousands of entries in testing decks. Much like the information streamed and collected from IoT-enabled products, this information hides crucial clues of problems in product development. The key is to uncover them.

Another characteristic of the big data in enterprise systems is that it is scattered. Engineering often uses PLM and Product Data Management. Manufacturing uses Manufacturing Operations Management, Manufacturing Execution Systems, and ERP. Sourcing and purchasing departments often have their own systems. Service and maintenance organizations use Field Service Management and Call Center systems. And there are many more. The data within any of these systems can be the key to discovering the source of product development issues.

The information scattered across the many enterprise systems within manufacturers is another important source of insight. Any solution considered must be able to work with the big data in many different locations.

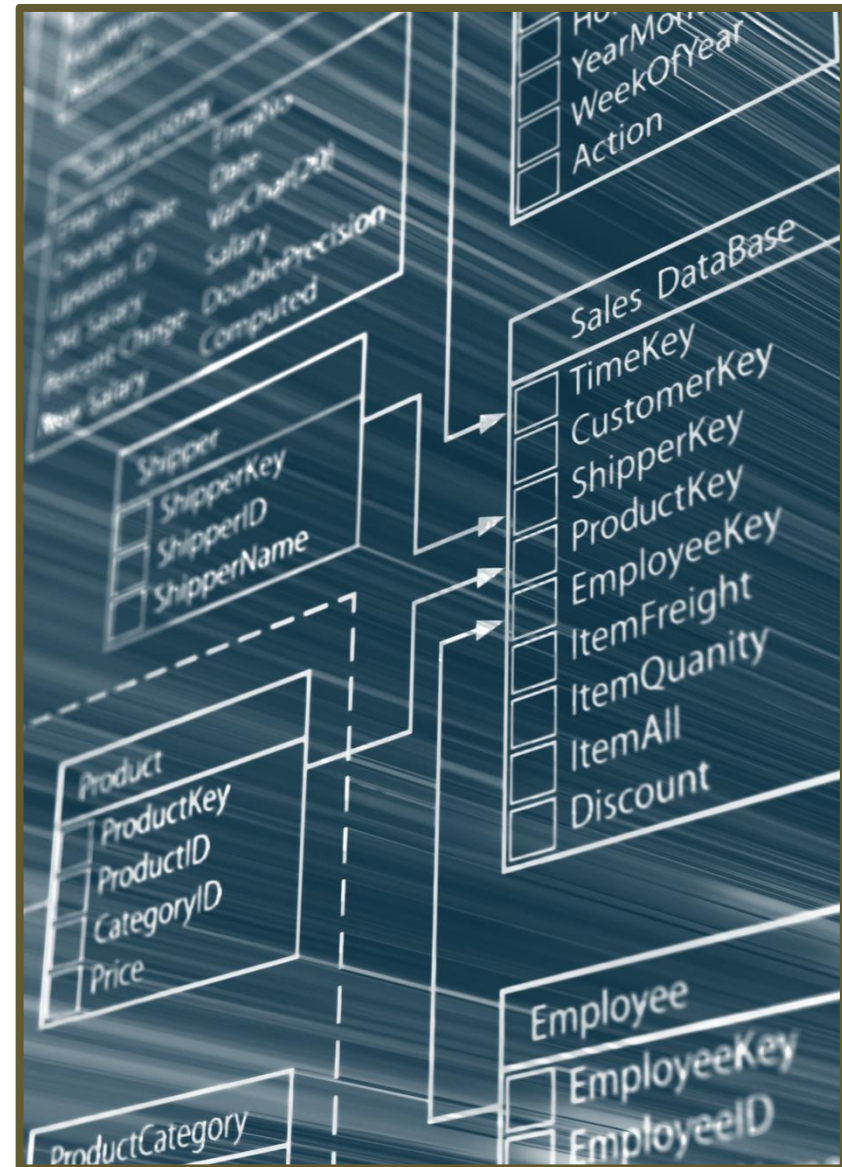

CONNECTING THE DATA MEANINGFULLY

Now, every company has access to their data in these forms. Each department can look at the information in their enterprise systems. Each one can analyze the data they have collected from their IoT-enabled products. Yet even if they did have some means to quickly and easily sift through their big data, evidence that a pending issue exists often only emerges from the *combination of data* from multiple systems. That means that the sign of a problem may only come to light when you combine the readings from a temperature sensor with the problem reports in the PLM system. A clue of another issue might only be noticeable when you mash up information from the sourcing system with data streaming from a strain gauge.

It is the combination of information from many different systems that offers actionable insight. Any solution that provides visibility must mash up data and information from a variety of sources.

FOLLOWING HINTS, WHEREVER THEY LEAD

The issues that can undermine product development are manifold. They may emerge from engineering. They might start from sourcing. The root cause might exist in manufacturing. It might come from a supplier. Additionally, the initial clue to the problem might come from anywhere. You pick up the trail in quality and follow it to regulatory compliance. You might find the first clue in marketing and follow it to a supplier.

Ultimately, you never know where you might pick up a hint about a problem. You never know where that sign might lead. That means any solution for visibility needs to offer the flexibility to drill down into the data without constraint, allowing executives to pick up a hint and follow it wherever it leads.

TAKEAWAYS

Visibility into product developments enables executives to identify and mitigate problems early, when they pose the least risk to the schedule and budget. However, there are barriers to gaining such actionable insight that demand specific solution capabilities.

- Big data comes in the form of sensor data from IoT-enabled products. Big data also exists in many different enterprise systems. Any eligible analytics solution must be able to connect and analyze such sources of information.
- The combination of this data often uncovers product development issues early. Any eligible analytics solution must be able to combine such sources of data for analysis.
- Clues of product development can be found anywhere, and it might lead anywhere. Any eligible analytics solution must let users drill down into information, even if it means crossing over from data from one source to another.

There are a range of solutions that could potentially offer visibility into product development. The question is whether they measure up to these capabilities.

PRODUCT DATA ANALYTICS SOLUTIONS: RIGHT SCOPE, RIGHT FIT

The reporting capabilities of PLM and other enterprise systems are powerful, each proving their value in different contexts. Yet, each is limited to giving insight into the data *in that solution*. Given that, a Product Data Analytics system that is separate yet connected to all of these other enterprise solutions is the right fit. However, such a system must have a few crucial capabilities to be effective.

CONNECTIVITY WITH OTHER SYSTEMS

As noted previously in this eBook, the clues to a problem in product development might be spread across big data that exists in multiple enterprise systems. It is only when such data is combined into a single view that such a hint can be exposed, allowing executives to take corrective action. This reality implies that any system that provides that visibility must be able to connect to all of the enterprise systems that touch product development.

Beyond connecting to such systems, the effectiveness of a Product Data Analytics solution also depends on its ability to understand the data in those systems. The context of data in PLM systems is dependent on product configurations and effectivity. The context of ERP systems lies in transactional data. Every enterprise system has a notional construct around which its data revolves. It is important that the Product Data Analytics solution understands this.

FLEXIBLE INTERACTIVE REPORTS

When it comes to hints about development issues, executives need to follow the clues, wherever they might lead. It is the flexibility to drill down and traverse such data that allows the root cause of problems to be found. As such, Product Data Analytics systems must provide this capability, allowing executives to follow the trail across the data from all enterprise systems that touch product development.



CLOUD-BASED ACCESSIBILITY

Beyond the capabilities fundamental to the effectiveness of any Product Data Analytics solution, cloud-infrastructure offers some significant advantages.

One advantage is its ready ability to connect cloud-based IoT and Product Data Analytics solutions with supplier systems. Because it exists in the cloud and not behind a firewall, these solutions can be connected to supplier cloud enterprise systems with less effort. Connecting with supplier on-premise systems is also easier.

Another advantage lies in the accessibility of cloud-based solutions. Such systems can be used anywhere and anytime, without any special IT setup. Cloud-based systems lend themselves more readily to mobile applications. This is critical as most executives are frequently on the go.

Lastly, cloud-based solutions can be acquired using a subscription service instead of a license purchase. Such a service requires an ongoing smaller operational expense (OpEx) instead of a large upfront capital expense (CapEx). This is often far easier to fit into an IT budget, and has a lower return on investment (ROI) threshold.

TAKEAWAYS

By using a Product Data Analytics solution integrated with IoT, product development leaders can gain the insight into development that they desperately need. However, these solutions require three critical capabilities to be effective.

1. They must connect with the IoT sources of data and enterprise systems that touch product development, allowing executives to catch problems as early.
2. They must offer the ability to flexibly drill down into the data, enabling executives to follow the clues of an issue wherever it might lead.
3. Cloud-based solutions provide numerous advantages, including easier integrations, accessibility anytime and anywhere as well as lower initial investments.

Overall, Product Data Analytics solutions allow executives to identify product issues early on, so they can take corrective action before those issues turn into full blown catastrophes that derail a project's or program's schedule and budget.

SUMMARY AND CONCLUSION

Modern development is extremely complicated, making it difficult for executives to deliver high quality products on time and under budget. Visibility into development allows executives to identify issues early and take corrective action, resolving problems before they become disastrous.

BARRIERS TO GAINING DEVELOPMENT INSIGHT

There are three main hindrances to gaining visibility into development. These frame the constraints that any effective solution must address to deliver value.

- Big data exists in IoT sources of information and many different enterprise systems. Any eligible solution must be able connect and work with that information.
- Actionable insight often emerges from the combination of data from multiple sources. Any relevant solution must be able to combine such information.
- Clues of development can be found anywhere and lead anywhere. This means that relevant solutions must offer flexible drill down capabilities.

PRODUCT DATA ANALYTICS SOLUTIONS

Product Data Analytics solutions can deliver the visibility into product development that executives need based on three sets of key capabilities, including:

1. They connect with the IoT sources of data and enterprise systems that touch development, allowing executives to catch problems as early as possible.
2. They must offer the ability to flexibly drill down into the data, enabling executives to follow the clues of an issue wherever it might lead.
3. Cloud-based solutions provide numerous advantages, including easier integrations, accessibility anytime and anywhere as well as lower initial investments.

FINAL TAKEAWAYS

Gaining visibility into product development is a crucial capability that allows executives to identify and mitigate issues. Product Data Analytics tools with capabilities in three distinct areas can provide the right solution to gain insight.

© 2017 LC-Insights LLC



Chad Jackson is an analyst, researcher, and blogger with [Lifecycle Insights](#), providing insights on technologies that enable engineering, including CAD, CAE, PDM & PLM. chad.jackson@lifecycleinsights.com.